

Gabriel's Wedding Cake

Julian F. Fleron

The College Mathematics Journal, January 1999, Volume 30,
Number 1, pp. 35-38

Julian Fleron (j_fleron@foma.wsc.ma.edu) has been Assistant Professor of Mathematics at Westfield State College since completing his Ph.D. in several complex variables at SUNY University at Albany in 1994. He has broad mathematical passions that he strives to share with all of his students, whether mathematics for liberal arts students, pre-service teachers, or mathematics majors. Family hobbies include popular music, cooking, and restoring the family's Victorian house.

We obtain the solid which nowadays is commonly, although perhaps inappropriately, known as Gabriel's horn by revolving the hyperbola $y = 1/x$ about the line $y = 0$, as shown in Fig. 1. (See, e.g., [2], [5].) This name comes from the archangel Gabriel who, the Bible tells us, used a horn to announce news that was sometimes heartening (e.g. the birth of Christ in Luke 1) and sometimes fatalistic (e.g. Armageddon in Revelation 8-11).

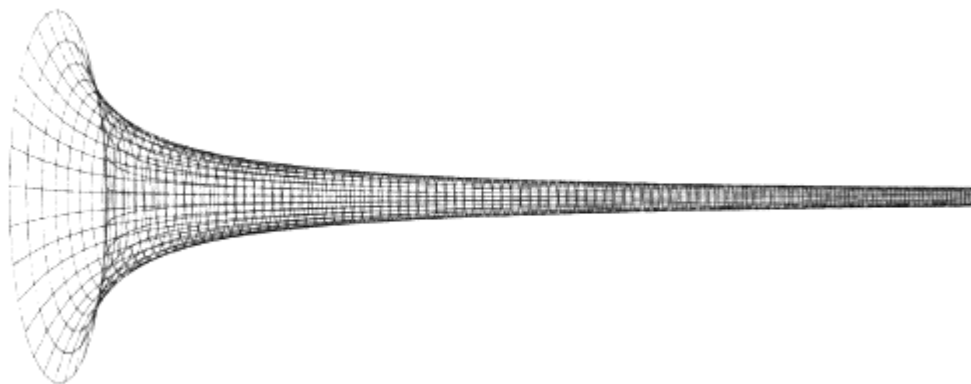

Figure 1. Gabriel's Horn.

This object and some of its remarkable properties were first discovered in 1641 by Evangelista Torricelli. At this time Torricelli was a little known mathematician and physicist who was the successor to Galileo at Florence. He would later go on to invent the barometer and make many other important contributions to mathematics and physics. Torricelli communicated his discovery to Bonaventura Cavalieri and showed how he had computed its volume using Cavalieri's principle for indivisibles. Remarkably, this volume is finite! This result propelled Torricelli into the mathematical spotlight, gave rise to many related paradoxes [3], and sparked an extensive philosophical controversy that included Thomas Hobbes, John Locke, Isaac Barrow and others [4].

This solid is a favorite in many calculus classes because its volume can be readily computed via the method of disks:

$$V = \int_1^{\infty} \pi(f(x))^2 dx = \int_1^{\infty} \pi \frac{1}{x^2} dx = \lim_{n \rightarrow \infty} \left(\pi \frac{-1}{x} \Big|_1^n \right) = \pi.$$

The seeming paradox of an infinite solid with a finite volume becomes even more striking when one considers its surface area. The standard method for computing areas of surfaces of revolution gives

$$\begin{aligned}
 S &= \int_1^\infty 2\pi f(x) \sqrt{1 + (f'(x))^2} dx = \int_1^\infty 2\pi \left(\frac{1}{x}\right) \sqrt{1 + \left(\frac{-1}{x^2}\right)^2} dx \\
 &= \int_1^\infty 2\pi \frac{\sqrt{x^4 + 1}}{x^3} dx.
 \end{aligned}$$

This last integral cannot be evaluated readily, although with the aid of a computer algebra system we find

$$\int 2\pi \frac{\sqrt{x^4 + 1}}{x^3} dx = \pi \left[\ln(\sqrt{x^4 + 1} + x^2) - \frac{\sqrt{x^4 + 1}}{x^2} \right] + C.$$

In lieu of this, typically we estimate $\sqrt{x^4 + 1}/x^3 \geq \sqrt{x^4}/x^3 = 1/x$ so

$$S = \int_1^\infty 2\pi \frac{\sqrt{x^4 + 1}}{x^3} dx \geq 2\pi \int_1^\infty \frac{dx}{x} = \lim_{n \rightarrow \infty} (|\ln(x)|_1^n) = \infty.$$

Hence, Gabriel's horn is an infinite solid with finite volume but infinite surface area!

Although Gabriel's horn is an engaging and appropriate example for second semester calculus, analysis of its remarkable features is complicated by two factors. First, many of the new calculus curricula do not include areas of surfaces of revolution. Second, the beauty of the paradox is often obscured by an integral estimate that most students find spurious at best.

In an effort to alleviate these factors, as well as to find an example accessible to less advanced students, we can use a discrete analogue of Gabriel's horn to illustrate the same paradox. To construct it we can replace the function $y = 1/x$ with a step function. Let

$$f(x) = \begin{cases} 1 & \text{for } 1 \leq x < 2 \\ \frac{1}{2} & \text{for } 2 \leq x < 3 \\ \dots & \dots \\ \frac{1}{n} & \text{for } n \leq x < n + 1 \\ \dots & \dots \end{cases}$$

Revolving the graph of f about the line $y = 0$ we obtain the solid of revolution shown in Fig. 2. Notice that, when stood on end, it appears to be a cake with infinitely many layers.

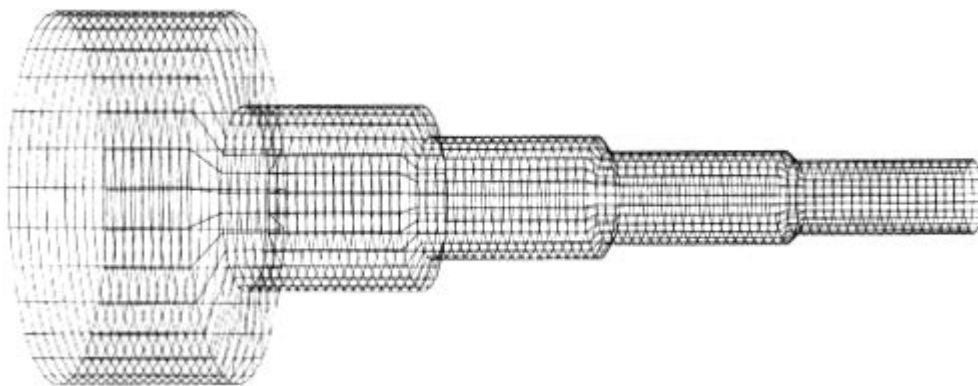

Figure 2. Gabriel's Wedding Cake

As each layer is simply a cylinder, the volume and surface area of the solid can be readily computed. The n th layer has volume $\pi(1/n)^2$, so the total volume of the cake is

$$V = \sum_{n=1}^{\infty} \pi \left(\frac{1}{n} \right)^2 = \pi \sum_{n=1}^{\infty} \frac{1}{n^2}.$$

This series converges. Calculus students will recognize the series as a p -series with $p = 2$. Less advanced students can see that the series converges by comparison:

$$\begin{aligned} \sum_{n=1}^{\infty} \frac{1}{n^2} &= 1 + \frac{1}{2^2} + \frac{1}{3^2} + \frac{1}{4^2} + \frac{1}{5^2} + \frac{1}{6^2} + \frac{1}{7^2} + \dots \\ &\leq 1 + \frac{1}{2} \left(\frac{1}{2} + \frac{1}{2} \right) + \frac{1}{4} \left(\frac{1}{4} + \frac{1}{4} + \frac{1}{4} + \frac{1}{4} \right) + \dots \\ &= 1 + \frac{1}{2} + \frac{1}{4} + \dots = \frac{1}{1 - \frac{1}{2}} = 2. \end{aligned}$$

Using Euler's remarkable result that the sum of the series is $\sum_{n=1}^{\infty} (1/n^2) = \pi^2/6$ [1], one can even obtain an exact result: $V = \pi^3/6$.

The surface area is formed by the annular tops and the lateral sides of each layer. The surface area of the n th annular top is $\pi(1/n)^2 - \pi(1/n + 1)^2$, so the total area of the annular tops is given by the telescoping series

$$A_T = \sum_{n=1}^{\infty} \left[\pi \left(\frac{1}{n} \right)^2 - \pi \left(\frac{1}{n+1} \right)^2 \right] = \pi.$$

Notice this result is obvious if one "collapses" the layers since the resulting top layer will be a complete disk of radius one. The surface area of the n th lateral side is $2\pi(1/n)(1)$, so the total lateral surface area is

$$A_L = \sum_{n=1}^{\infty} 2\pi \left(\frac{1}{n} \right) (1) = 2\pi \sum_{n=1}^{\infty} \frac{1}{n}.$$

This is the harmonic series, among the most important of all the infinite series, which diverges.

Thus, this solid illustrates essentially the same paradox as Gabriel's horn: an infinite solid with finite volume and infinite surface area. In other words: a cake you can eat, but cannot frost.

Regarding a name for this new solid, Gabriel's wedding cake seems appropriate for physical and genological reasons. In addition, it seems a bit refreshing since weddings are so unabashedly joyous, and the connotations of the horn have often imposed a heavy burden on Gabriel.

References

1. William Dunham, *Journey Through Genius*, John Wiley & Sons, 1990.
2. P. Gillett, *Calculus and Analytic Geometry*, 2nd ed., D. C. Heath, 1984.
3. Jan A. van Maanen, Alluvial deposits, conic sections, and improper glasses, or history of mathematics applied in the classroom, in F. Swetz, J. Fauvel, O. Bekken, B. Johansson, and V. Katz, eds., *Learn from the Masters*, Mathematical Association of American, 1995.
4. Paolo Mancosu and Ezio Vailati, Torricelli's infinitely long solid and its philosophical reception in the seventeenth century, *Isis*, 82:311 (1991) 50-70.
5. D. W. Varerg and E. J. Purcell, *Calculus*, 7th ed., Prentice Hall, 1997.